

SIMPLIE

3x2 수납장 6문 BC135

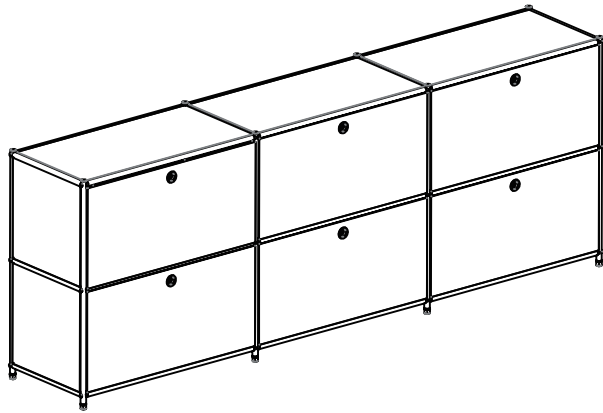

[취급주의]

- 가구사용시 인위적으로 휘발성있는 물질을 흘렸을 경우 가구표면의 손상이 발생하오니 주의하세요.
- 무리한 힘이나 충격을 가하지 마시고 수평을 유지하여 사용하세요.
- 직사광선이나 강한열 혹은 촉한을 피해주세요.
- 이동시 끌지마시고 들어서 이동하여 주세요.
- 테이프나 접착용품은 제품에 훼손을 일으킬수 있으니 주의하세요.
- 교환/취소/반품/환불 관련사항은 사이트 참조바랍니다.

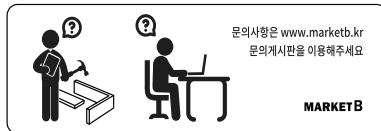
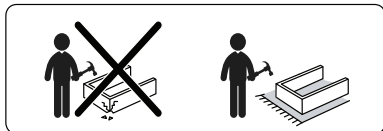

TIP

조립전 부품의 이상유무를 반드시 확인해주세요.

	부품명	수량		부품명	수량
	(A) 바닥패드	8		(H) 나사 4 (M4x12)	18
	(B) 나사 1(M6x45mm)	12		(I) 왼쪽 힌지	6
	(C) 캡	36		(J) 오른쪽 힌지	6
	(D) 힌지 부품	48		(K) 나사 5 (M4x8mm)	24
	(E) 나사 2 (M5x14mm)	48		(L) 앵커볼트	2
	(F) 나사 3 (M6x55mm)	12		(M) 벽고정용 브라켓	2
	(G) 육각렌치	1		(N) 벽고정용 나사 (M5x40mm)	2

	부품명	수량
	(1) 왼쪽,오른쪽 프레임 /패널 1A: 왼쪽,오른쪽 패널 1B: 왼쪽,오른쪽 프레임	2
	(2) 중간 프레임/패널 2A: 중간 패널 2B: 중간 프레임	2
	(3) 가로 프레임	18
	(4) 패널	15
	(5) 문	6

1 ※ 조립 전 프레임과 패널을 분리해 주세요.

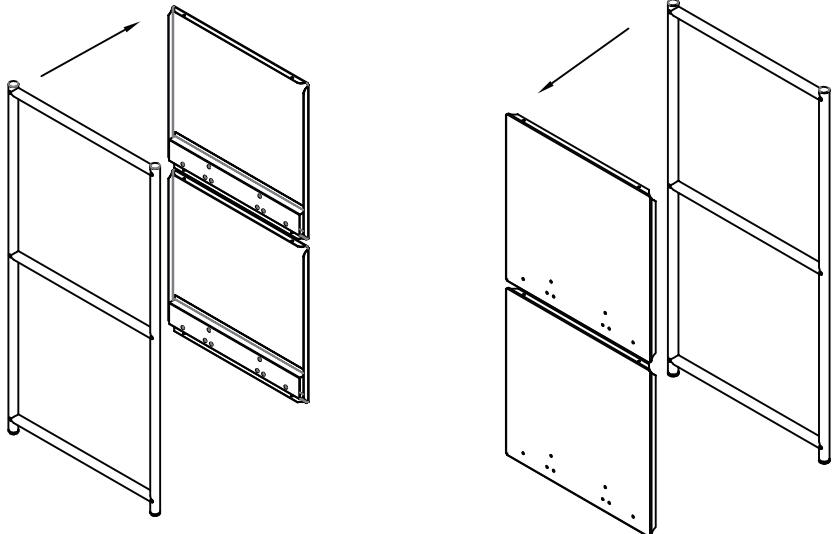

(1) 왼쪽,오른쪽 프레임 /패널 x 2

(2) 중간 프레임/패널 x 2

2-1 각 패널에 힌지를 조립해 주세요.

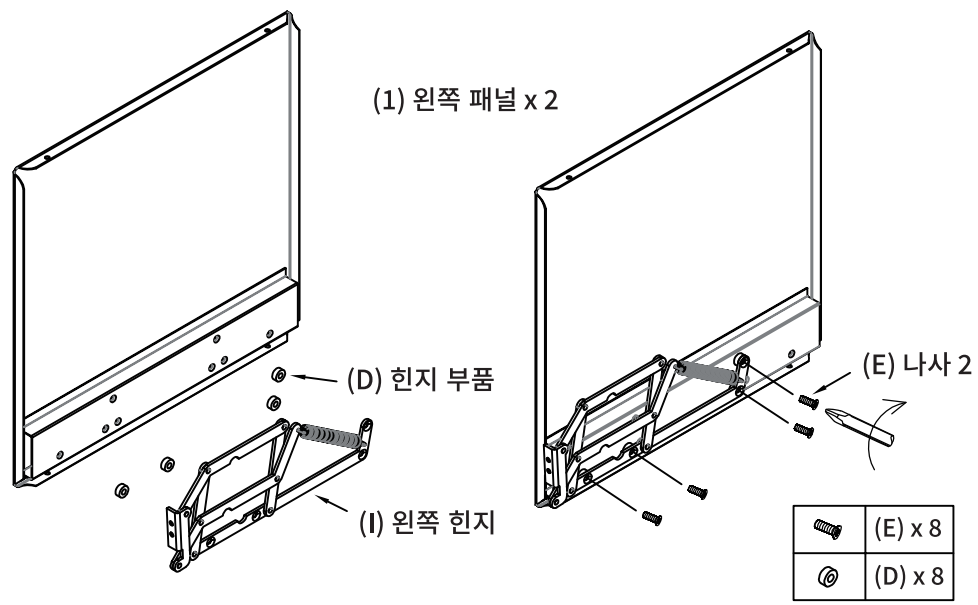

(1) 왼쪽 패널 x 2

(D) 힌지 부품

(I) 왼쪽 힌지

(E) 나사 2

	(E) x 8
	(D) x 8

2-2

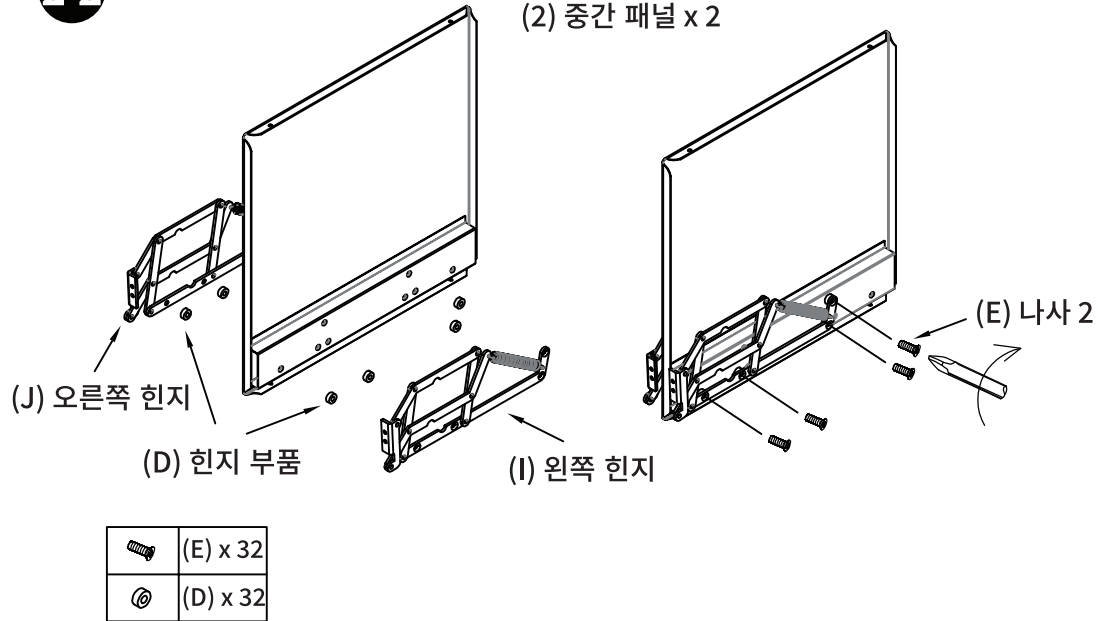

(2) 중간 패널 x 2

(J) 오른쪽 힌지

(D) 힌지 부품

(I) 왼쪽 힌지

(E) 나사 2

	(E) x 32
	(D) x 32

2-3

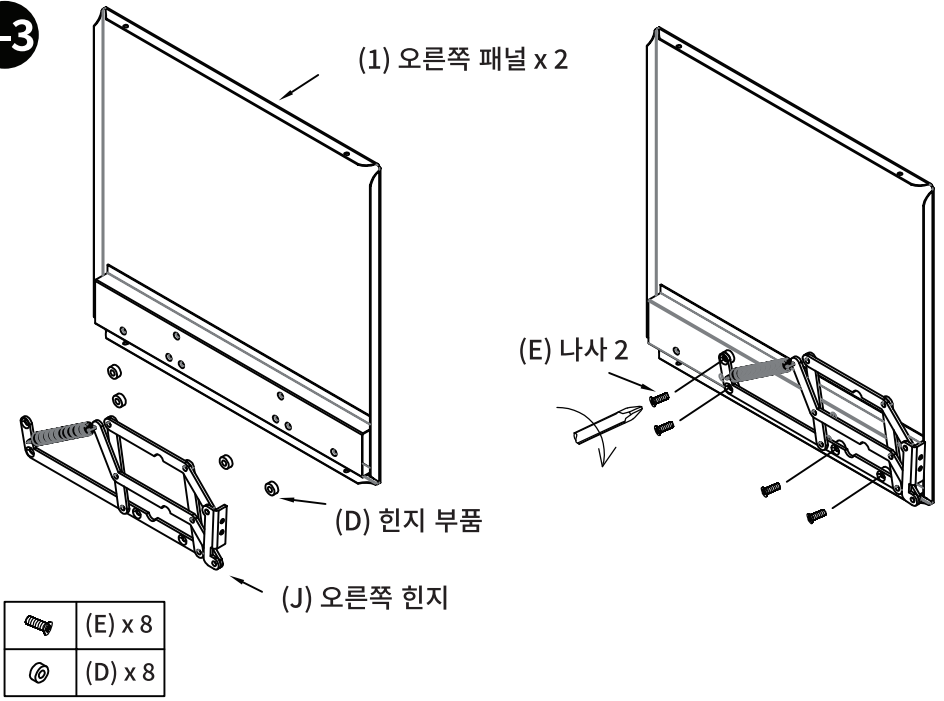

(1) 오른쪽 패널 x 2

(D) 힌지 부품



(J) 오른쪽 힌지

(E) 나사 2

	(E) x 8
	(D) x 8

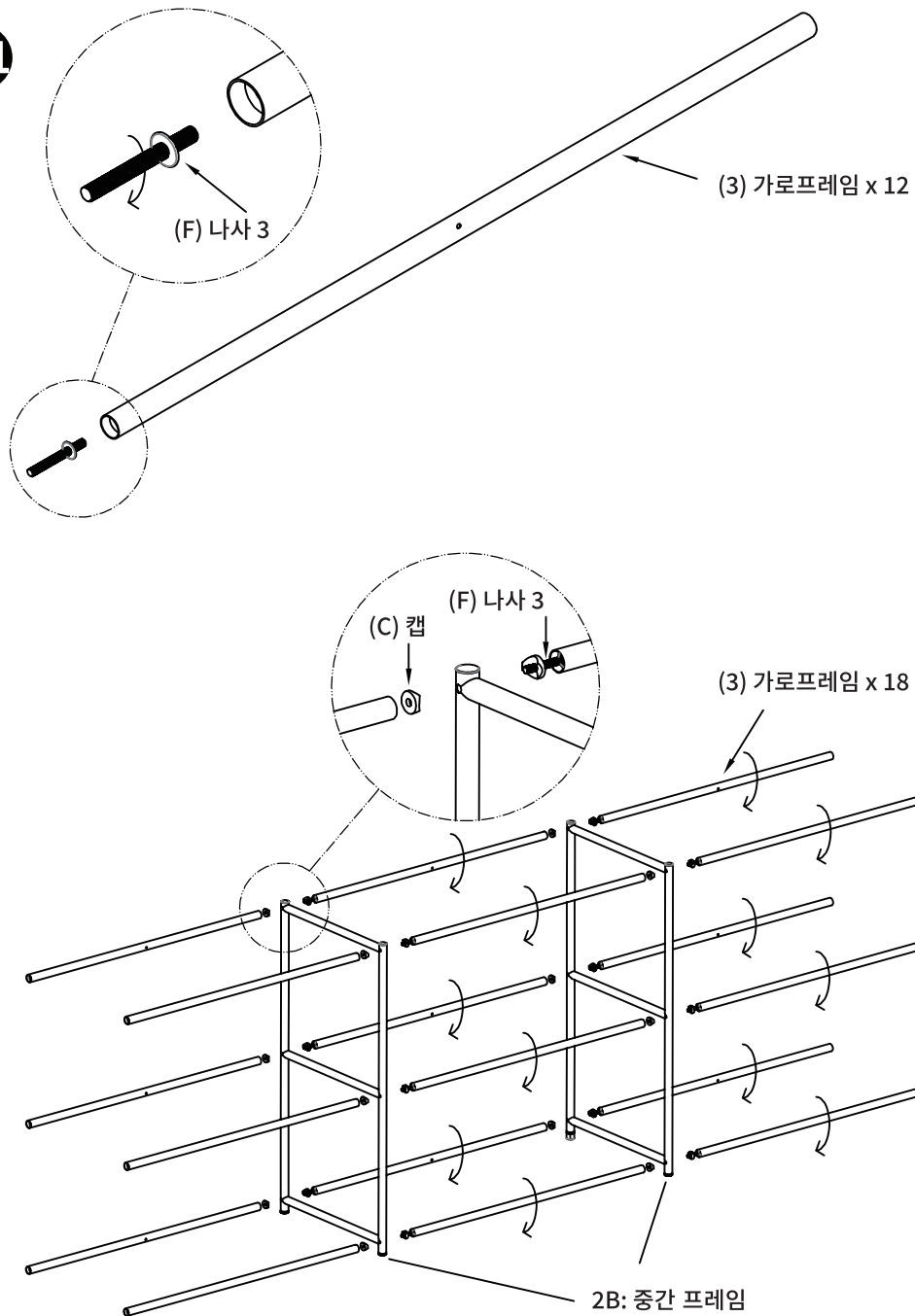

3-1

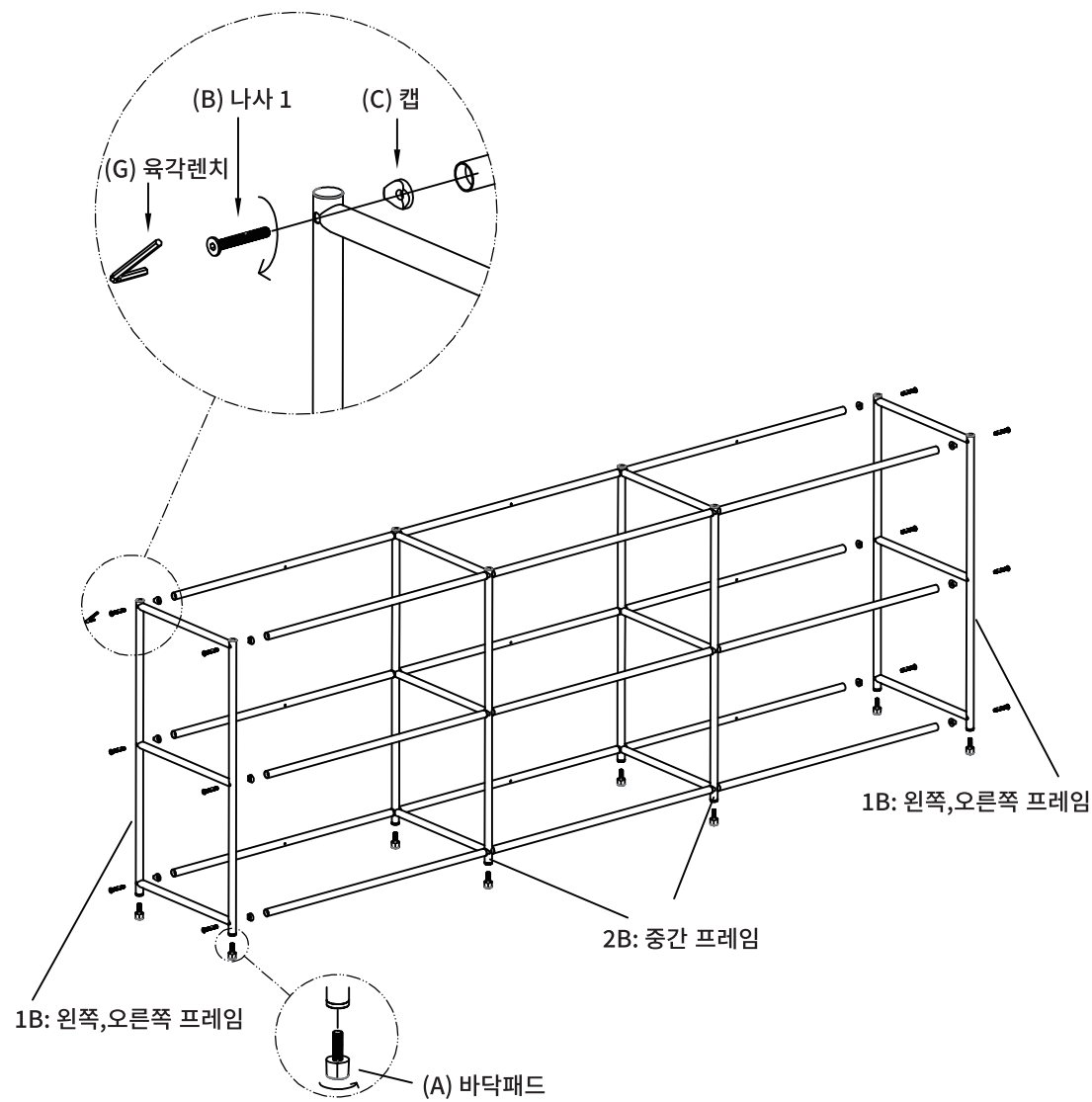

	(F) x 12
	(C) x 24

3-2



	(B) x 12
	(C) x 12
	(A) x 8

4

조립순서

(4) 패널 → (H) 나사 4 → 1A: 왼쪽,오른쪽 패널 → 2A: 중간 패널

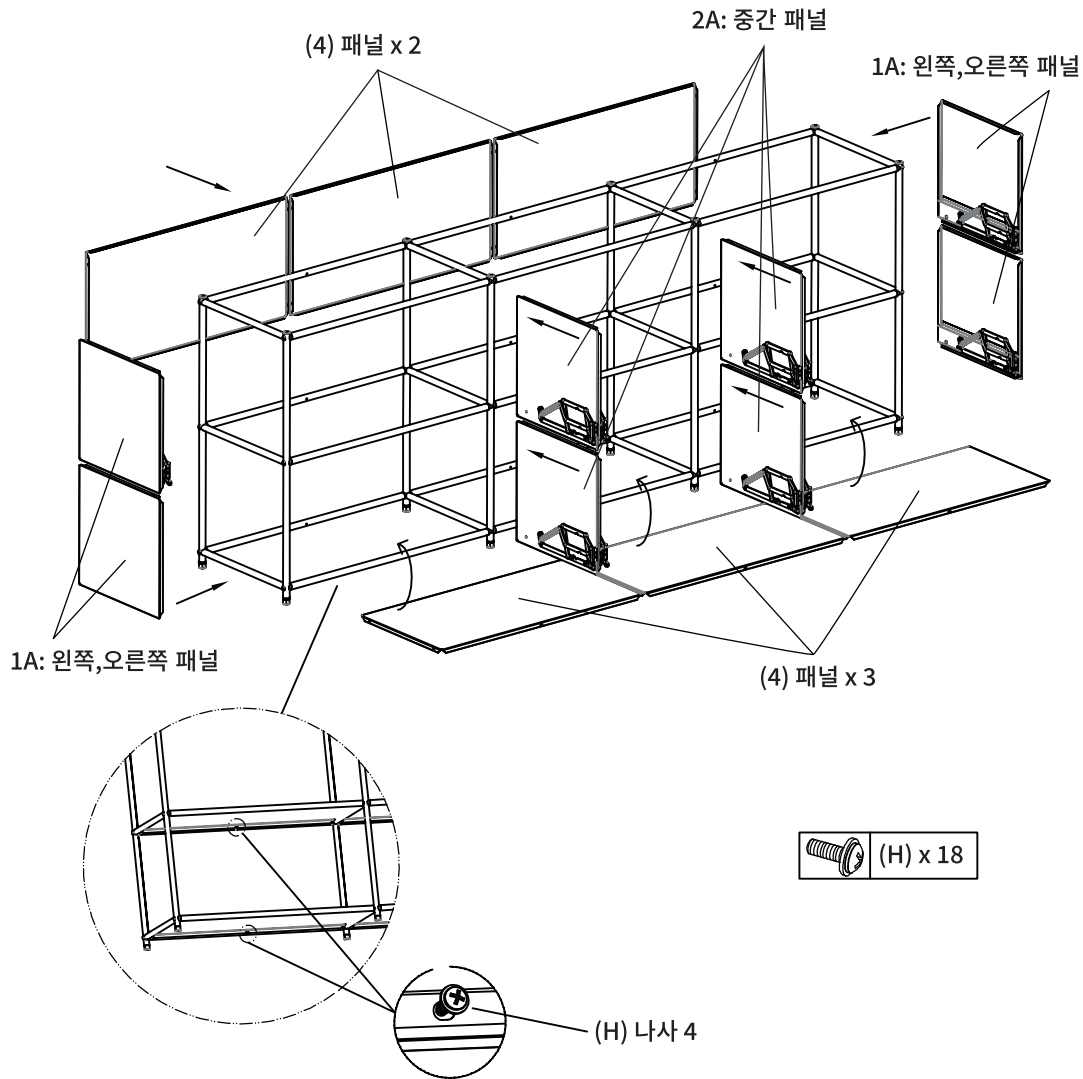



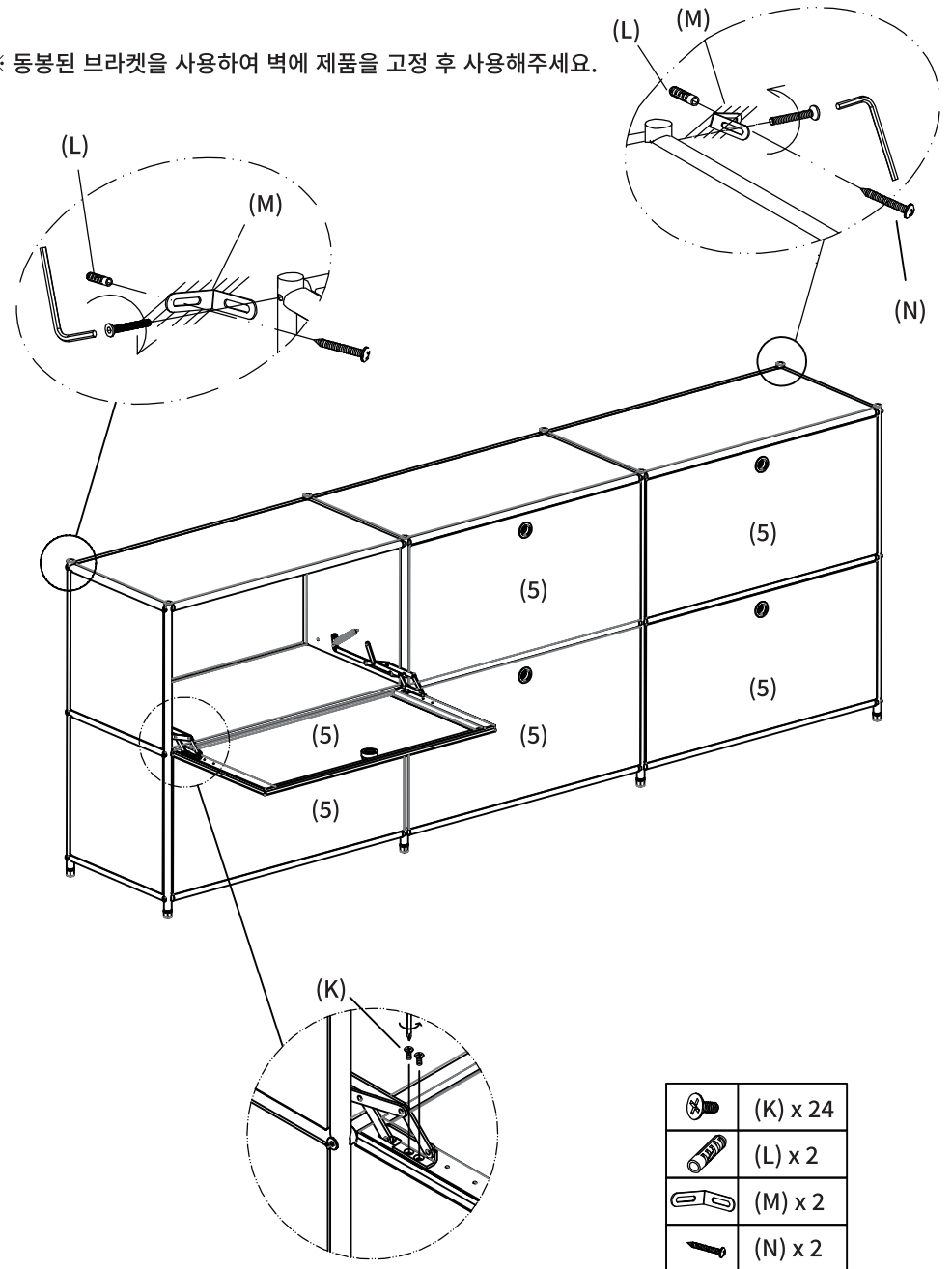

5



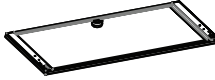







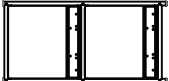

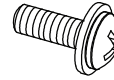

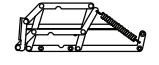
※ 동봉된 브라켓을 사용하여 벽에 제품을 고정 후 사용해주세요.

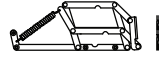

SIMPLIE 3x2 수납장 6문 BC135 포장구성

3-1		
	(4)	6
	(5)	4
	(3)	9

3-2		
	(3)	9
	(4)	9
	(5)	2

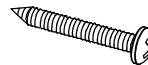
3-3					
	(1)	2		(G)	1
	(2)	2		(H)	18
	(A)	8	 L	(I)	6
	(B)	12	 R	(J)	6
	(C)	36		(K)	24
	(D)	48		(L)	2
	(E)	48		(M)	2
	(F)	12		(N)	2